

HYDRAULIC DRILLING UNIT

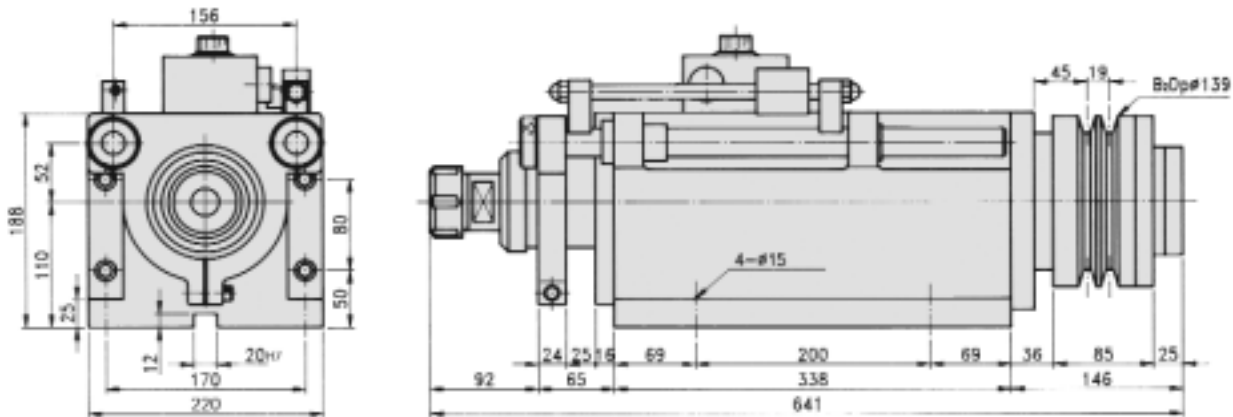

Model FD75-100

Specifications (Unit: metric)

Hydraulic Pressure	280 ~ 490 P.S.I.
Drilling Capacity	1 1/4" (steel)
Stroke	4"
Max. Revolution/Minute	1,000RPM
Flow Control Valve	FCC-G03-8
Weight	187 lb
Cylinder Diameter	4.33"
Cylinder Area	Forward 11.0 IN ² , Backward 6.95 IN ²
Thrust Force	3124 lb @ 280 P.S.I.

Consumption Parts

O-Ring for Front Cover	P-80x2, G-105x3, DH-80x1
O-Ring for Piston	P-100x2, G-65x1
O-Ring for Rear Cover	P-55x2, G-105x1
Spindle Bearing	32008x1, 32007x1, 6007Zx1, 6008Zx1
Pulley Bearings	6013Zx1, 51213x1

Features

- High RPM application is available, specify this requirement when placing order.
- Left side mounted fitting holes and flow control valve are available, specify this requirement when placing order.
- Capable of $\pm .0005$ with short dwell.
- If mounting multiple spindle head to this unit, please choose nose type: FD-75-100MT3A is recommended.



Spindle Options

(See page 52 for drawings and dimensions)

ER40	Pg. 52
FB30	Pg. 52
FD75-100-MT3A Multi	Pg. 52