

# FLOOR MOUNTED DRILLING AND TAPPING PRESSES



HD-250 (Semi-Automatic)  
HDT-25 (Tapping)  
HDT-32 (Tapping)



HD-PAM-520L



HD-PAM-750  
(Base Optional)

## Models HD-250, HDT-25, HDT-32, HD-PAM-520L, HD-PAM-750

### Specifications (Unit: inch)

Type	Semi-Automatic Feeding Machine	Manual Tapping Machine	Manual Tapping Machine	Pneumatic Machine
Model	HD-250	HDT-25	HDT-32	HD-PAM-520L
Spindle Taper	MT: 3	MT: 3	MT: 3	MT: 3
Taper of Spindle Nose	JT: 2-1/2	JT: 2-1/2	JT: 4	JT: 2-1/2
Max. Drilling Capacity in Steel	Ø1"	Ø11/16"	Ø1-1/4"	Ø1/2"
Spindle Stroke	5"	5-1/2"	5-1/2"	140
Electric Motor	2HP	2HP	2HP	1HP
Number of Speeds	9	9	4	9
Speed RPM (50Hz)	200 to 1600	160 to 1342	55 to 175	-
Speed RPM (60Hz)	210 to 1700	190 to 1610	65 to 210	230 to 2380
Weight (lb) Without Motor	379	355	397	-
Weight (lb) With Motor	436	412	454	460

These drilling and tapping presses are ideal for lower volume applications or for a variety of applications where changeover occurs often. They can be used as flexible, stand-alone machine systems or tooled and fixtured for short production runs. A small PLC can be incorporated into some models. Multiple presses can be mounted to a common base for a dedicated "cell."

Other models beyond what are shown here are available upon request.

### Optional

Hause Machines can provide optional bases, coolant systems, multiple spindle heads and fixtures with any of the drilling and tapping presses shown in this catalog.

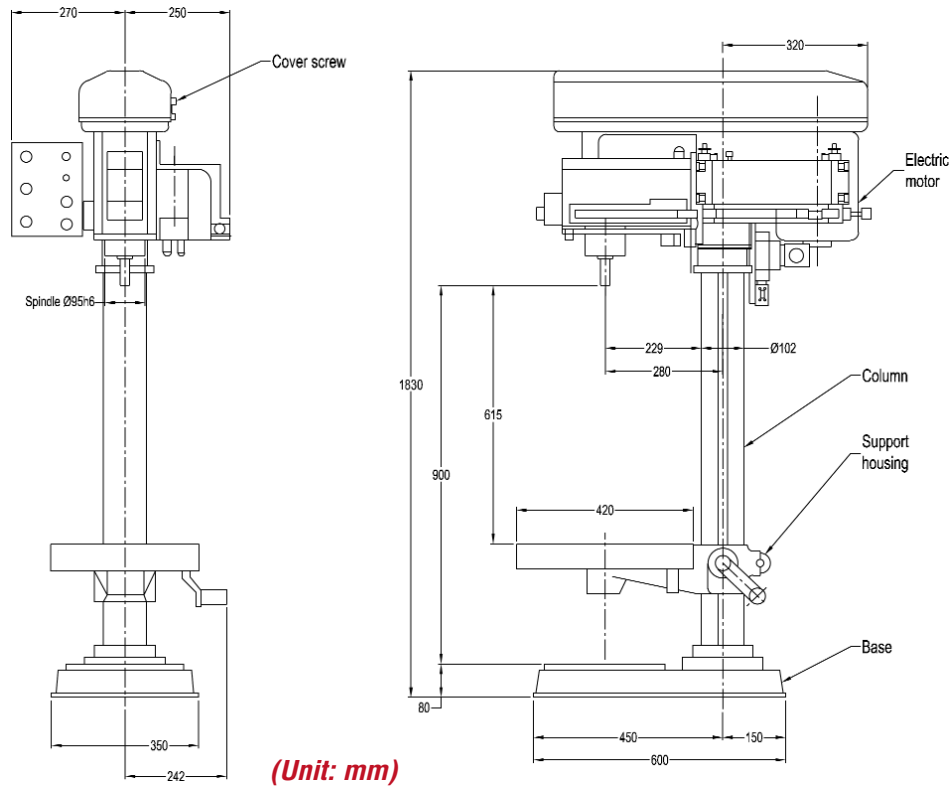

## Special Feed Options

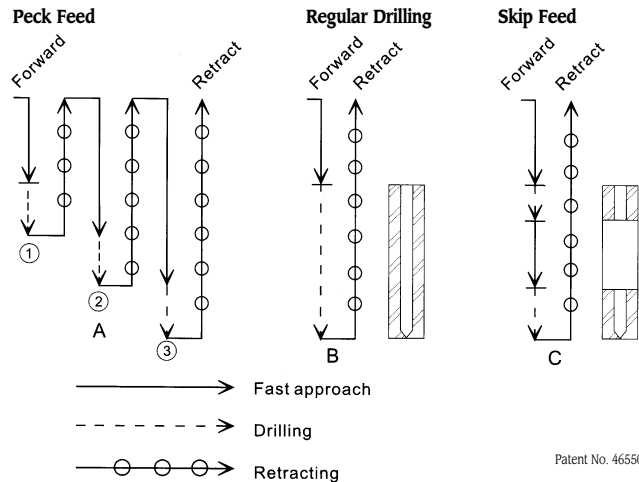

- Feeding speed can be adjusted in variable steps. Operation is easy and convenient.
- Use peck feed to remove chips from deep hole operation drilling. Number of retracts is adjustable.
- After retraction, drill will quickly approach to previous position to save operation time.

## Features

- Manual, semi-automatic and automatic models
- Air-hydraulic and hydraulic models available
- 1HP to 3HP
- Bench models or standard 72" height available
- Adaptable for multi-spindle heads
- Base, coolant and shielding packages also available
- Available with peck feed and skip feed
- Quality job from stable and accurate feeding operation
- Machine equipped with fixed point return device to maintain accurate depth
- Digital electronic control system provides reliable operation

## Hydraulic Machine

### HD-PAM-750

MT: 3
JT: 2-1/2
Ø1"
140
2HP
9
-
190 to 1610
-
504